



Pony Testing International Group

报告编号(Report ID): I04013020521D~1

# 锂电池跌落测试报告

## Lithium Battery Drop Test Report



Sample Description  
& Model

Cylindrical Lithium-ion Battery F<sup>®</sup>18650 2000

Applicant

First New Energy Co., Ltd

Manufacturer

First New Energy Co., Ltd

PONY 谱尼测试  
Pony Testing International Group

www.ponytest.com

No.: I04013020521D

Code: i0d98j



Pony Testing International Group

## I. SAMPLE DESCRIPTION

Sample Description	Cylindrical Lithium-ion Battery	Sample Model	F®18650 2000
Applicant	First New Energy Co., Ltd		
Manufacturer	First New Energy Co., Ltd		
Nominal Voltage	3.6V	Rated Capacity	2000mAh
Outer package	Paper Box	Inner package	Paper Box
Dimensions	115×74×67mm	Cushion	---
Gross weight	0.5kg	Battery number	8Pcs/packing
Client date	2014-03-20	Finished date	2014-04-10
Packaging type	Package including lithium batteries.		

## II. REFERENCE METHOD

《Recommendations On The Transport Of Dangerous Goods-Model Regulations》  
(ST/SG/AC.10/1/Rev.18<sup>th</sup>)

## III. TEST ITEM

1.2m Drop test  
Gross Weight Measure

## IV. CONCLUSION

This package is capable of withstanding a 1.2m drop test in any orientation without damage to cells or batteries contained therein, without shifting of the contents so as to allow battery to battery contact and without release of contents. The weight of the package is 0.5kg gross mass.

Prepared by: *Linchaitin* Checked by: *chengpeng* Approved by: *liyou*

Issue Date: April 10, 2014

www.ponytest.com ☎Hotline 400-819-5688

Add: 北京市海淀区苏州街49-3号溢智大厦	Add: 上海市徐汇区桂平路680号35号楼4层	Add: 深圳市南山区创业路中兴工业城6栋1层	Add: 青岛市崂山区株洲路190号6层
Tel: (010) 82618116	Tel: (021) 64851999	Tel: (0755) 26050909	Tel: (0532) 88706866
Add: 天津市南开区红唐路冀实大厦10层	Add: 宁波市高新区新晖路150号二期4号楼4层	Add: 广州市海珠区敦和路189号海珠科技园3号楼7层	
Tel: (022) 27360730	Tel: (0574) 87736499	Tel: (020) 89224310	



Pony Testing International Group

## V. TEST METHOD

《Recommendations On The Transport Of Dangerous Goods-Model Regulations》(18<sup>th</sup>) Special Provision 188 of Chapter 3.3.

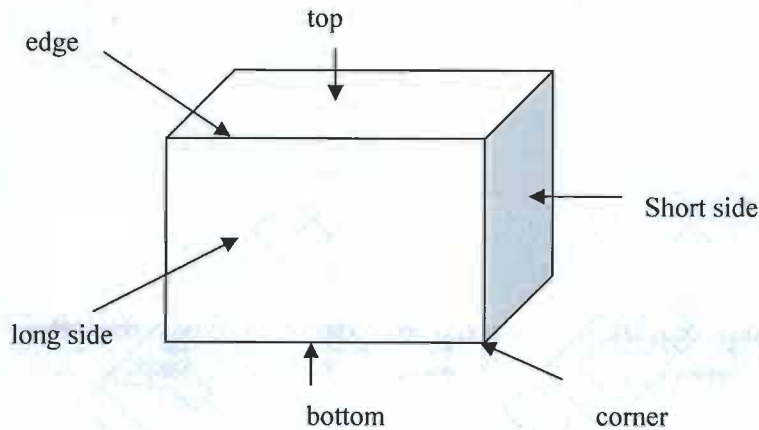

## VI. TEST APPARATUS

IE-0279 Drop test system

IE-0178 BALANCE

## VII. TEST ENVIRONMENT CONDITION

Ambient temperature: 20~25 (°C)

Ambient humidity: 50~60 (%)

## VIII. TEST DATA

1.2m Drop test	Side	Edge	Angle
Test Result	a. Without damage to cells or batteries contained therein; b. Without shifting of the contents so as to allow battery to battery (or cell to cell) contact; c. Without release of contents.		
Conclusion	The test package is capable of withstanding a 1.2m drop test in any orientation.		

www.ponytest.com ☎Hotline 400-819-5688

Add: 北京市海淀区苏州街49-3号盈智大厦  
Tel: (010) 82618116

上海市徐汇区桂平路680号35号楼4层  
(021) 64851999

深圳市南山区创业路中兴工业城6栋1层  
(0755) 28050909

青岛市崂山区株洲路190号6层  
(0532) 88706866

Add: 天津市南开区红旗路嘉苑大厦10层  
Tel: (022) 27360730

宁波市高新区新明路150号二期4号楼4层  
(0574) 87736499

广州市海珠区敦和路189号海珠科技园3号楼7层  
(020) 89224310



Pony Testing International Group

Test Item	Gross Weight Measure
Test Result	0.5kg
Conclusion	Passed

### IX. SAMPLE PHOTO



Authenticate the photo on original report only

\*\*\* End of report \*\*\*

www.ponytest.com Hotline 400-819-5688

Add: 北京市海淀区苏州街49-3号盈智大厦	Add: 上海市徐汇区桂平路680号35号楼4层	Add: 深圳市南山区创业路中兴工业城6栋1层	Add: 青岛市崂山区株洲路190号6层
Tel: (010) 82618116	Tel: (021) 64851999	Tel: (0755) 26050909	Tel: (0532) 88706866
Add: 天津市南开区红旗路富寰大厦10层	Add: 宁波市高新区新晖路150号二期4号楼4层	Add: 广州市海珠区敦和路189号海珠科技园3号楼7层	
Tel: (022) 27360730	Tel: (0574) 87736499	Tel: (020) 89224310	